Line Follower Robot Soldering Kit

1. Introduction.

There is a 16 mm wide black runway in the white field. Our tracking car can drive along the black runway automatically. No matter how the runway is bent, the car can be driven automatically. We all know that the reflectivity is different when the light source to the white objects and black objects. Here we use red light source. The light is reflected through the ground to the photoresistor. By detecting the resistance of the photosensitive resistor can determine whether the car is driving in the white area. If the detection is black runway, then the car to change the direction of driving and motor will slow down or even stop and Red LED OFF on PCB front side. Drive the car in the opposite direction so that the car is always running along the runway.

2. Overview.

- 1>. PCB Size:105*72*1.6mm
- 2>. Installation dimension:105*85*46mm
- 3>. Work Voltage:3V

3. Schematic.

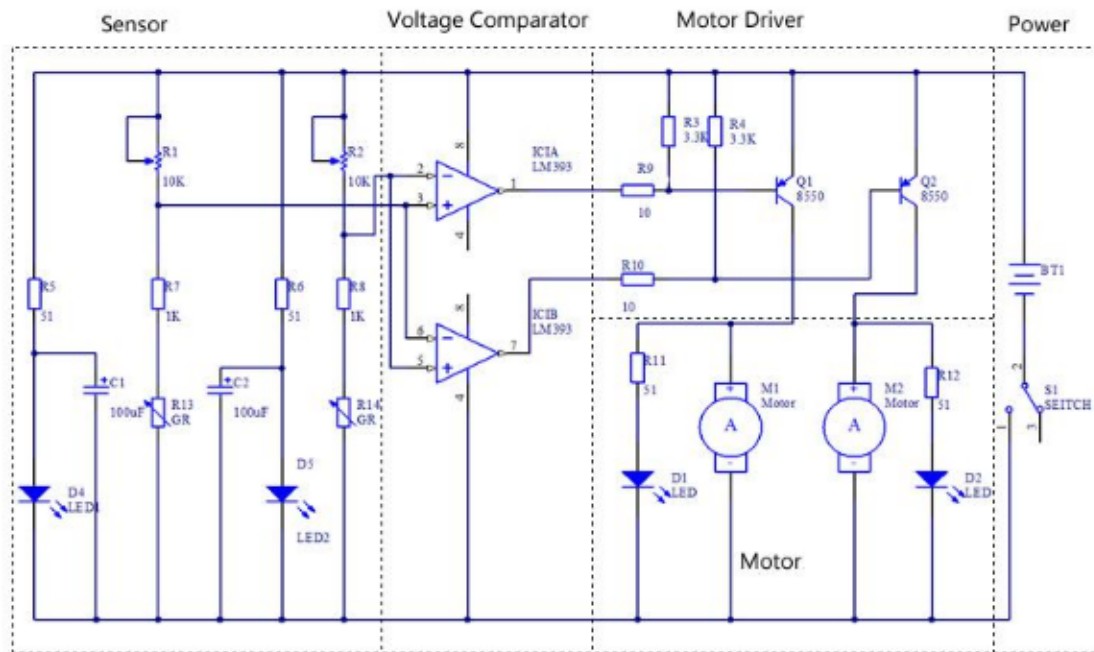

4. Component listing.

NO.	Component Name	PCB Marker	Parameter	Quantity
1	LM393	IC1	DIP-8	1
2	IC Socket	IC1	DIP-8	1
3	Electrolytic Capacitor	C1,C2	100uF	2
4	Potentiometer	R1,R2	103 10K	2
5	Metal Film Resistance	R5,R6,R11,R12	51ohm	4
6	Metal Film Resistance	R7,R8	1K	2
7	Metal Film Resistance	R9,R10	10ohm	2
8	Metal Film Resistance	R3,R4	3.3K	2
9	Photoresistor	R13,R14	CDS5	2
10	Red LED	D1,D2	5mm	2
11	White LED	D4,D5	5mm	2
12	S8550	Q1,Q1	TO-92	2
13	Self-Locking switch	S1	6*6mm	1
14	DC Motor	M1,M2		2
15	Wheel		40mm	2
16	Tires		40mm	2
17	Gaster Screw		M5*20mm	1
18	Gaster Nut		M5	1
19	Gaster Screw Cap		M5	1
20	Cable		6mm	4
21	Battery Case		AA*2	1
22	PCB D2-1		105*72*1.6mm	1

5. Installation Steps

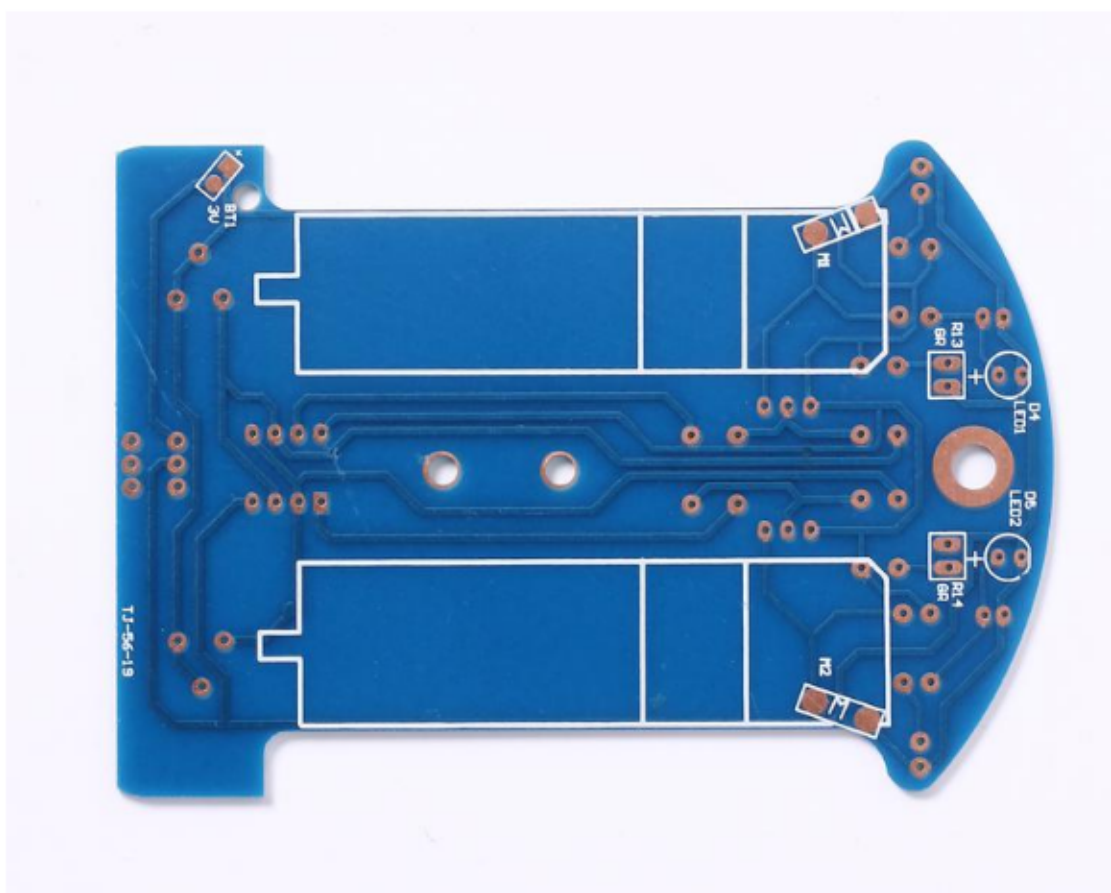
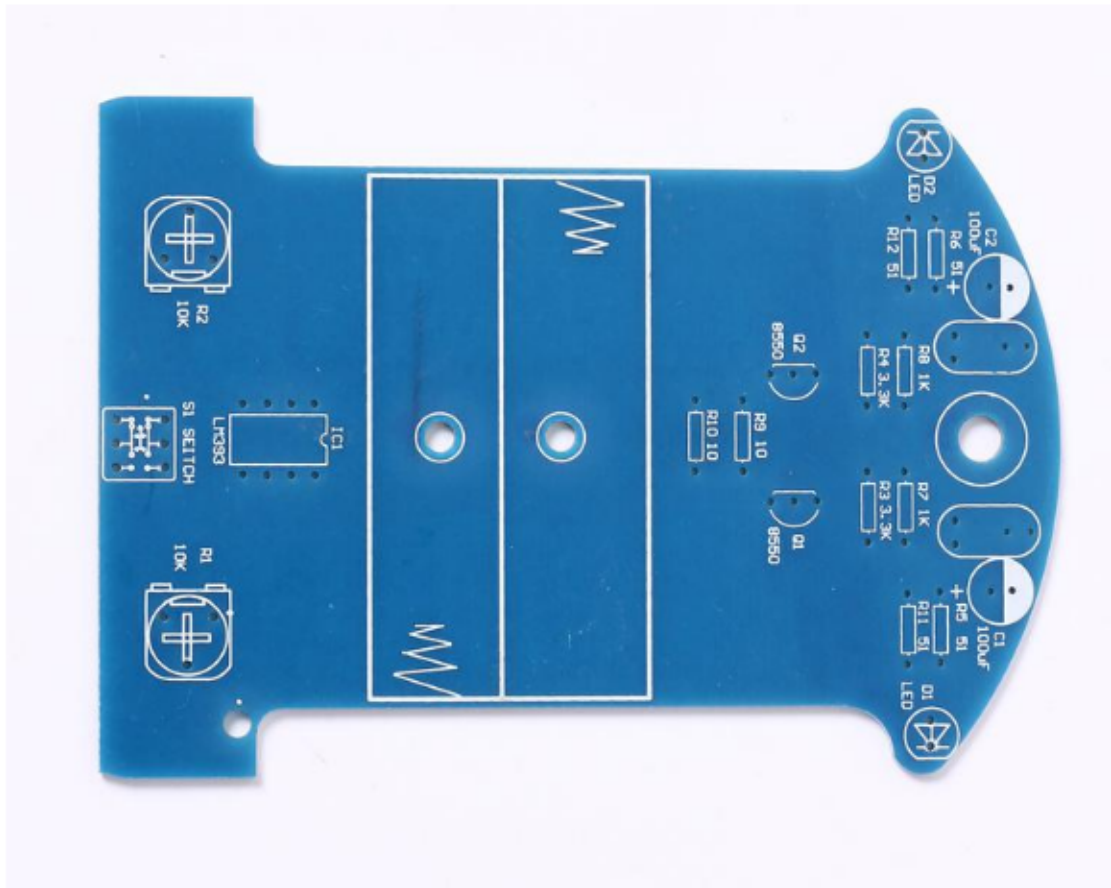

1>. Install metal film resistor,DIP-8P IC socket,Self-Locking switch,Potentiometer,S8550,Electrolytic capacitor,5mm Red LED on PCB according to mark on PCB.

1.1 Pay attention to the direction of IC Socket.

1.2 In addition to facilitate debugging, don't install IC LM393 temporarily .

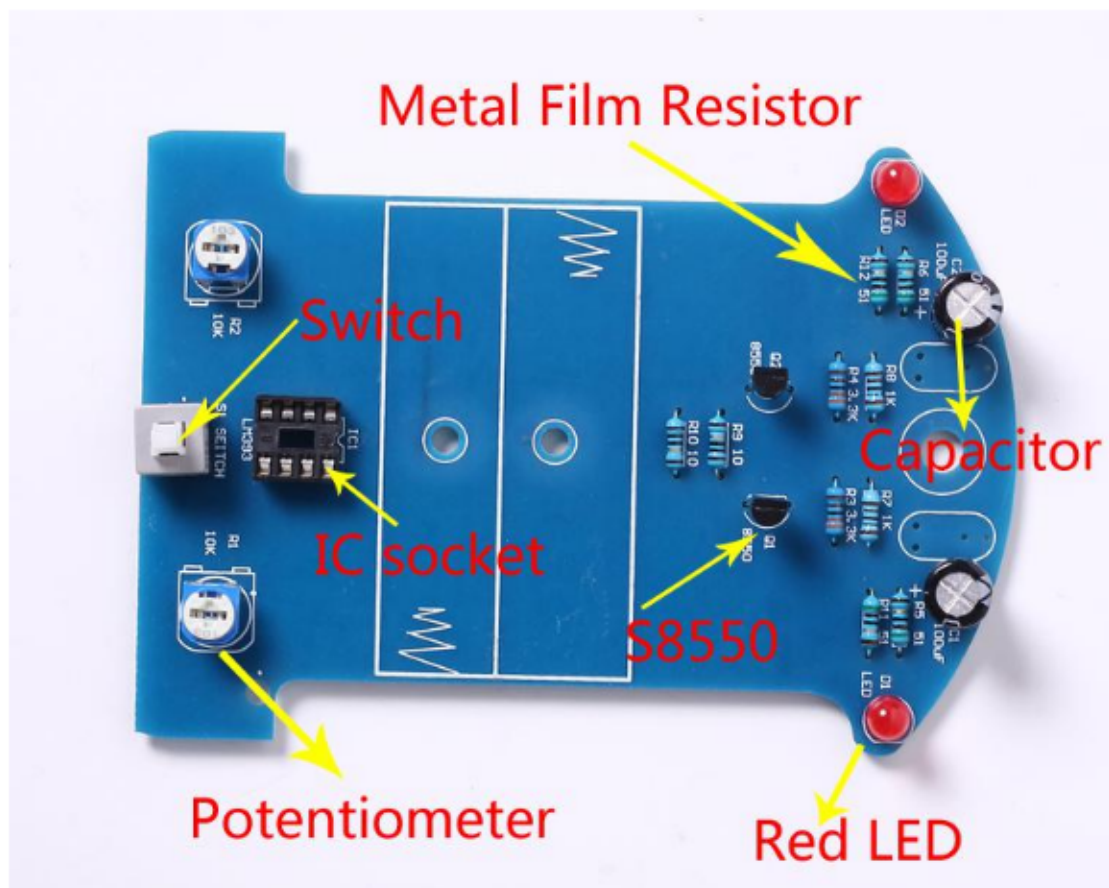

2>. PCB placed in front.The support bolts of the caster are inserted into the hole, tighten the nuts screwed into the caster, and finally fit the caster and tighten.

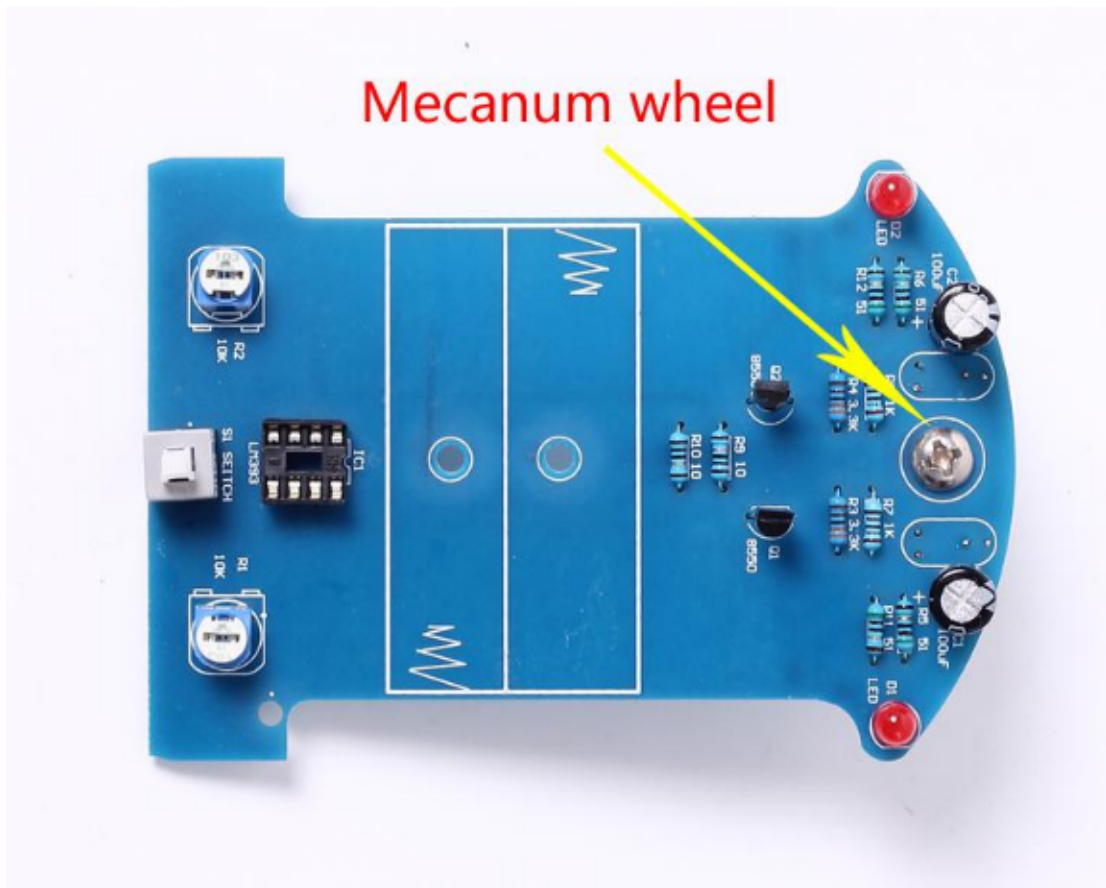

3>. Install photoresistor and white LED on PCB reverse. But please make sure the distance is about 5mm between top of mecanum wheel (top of screw cap top) and photoresistor/LED.

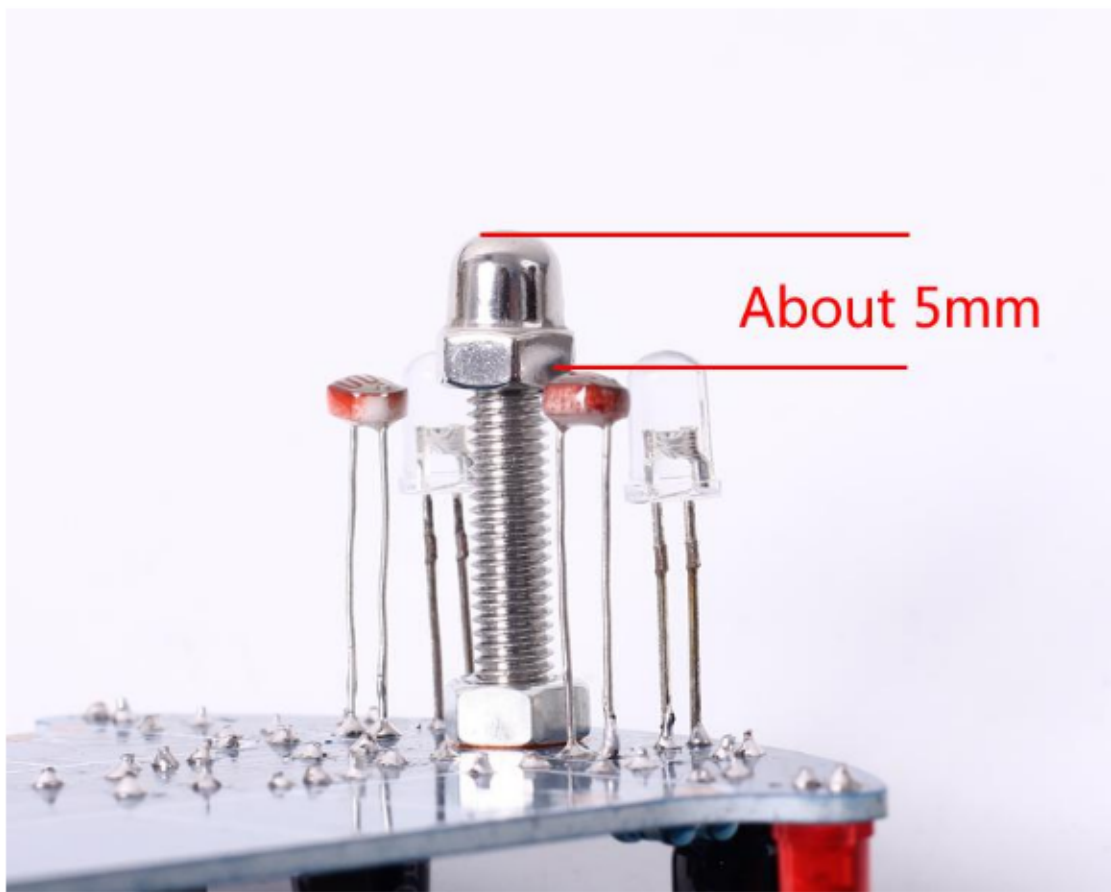
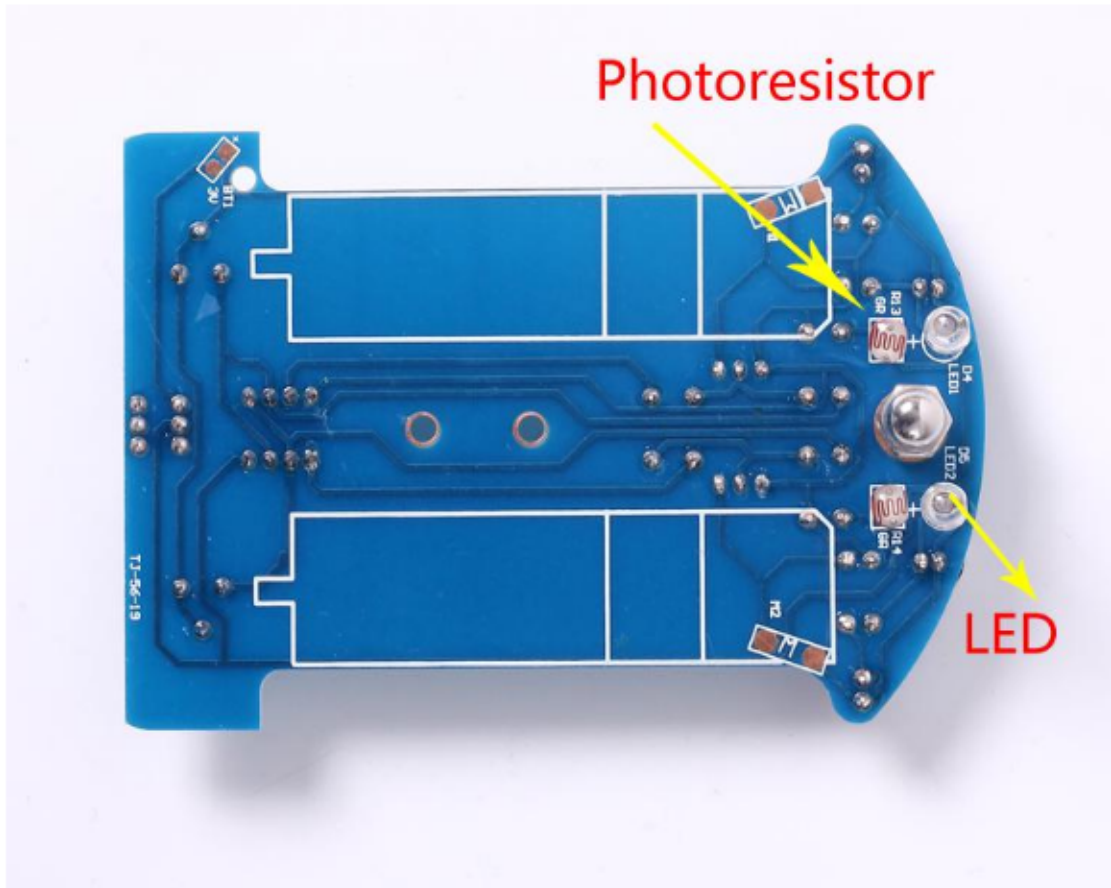

4>. Install 2pcs Motor.

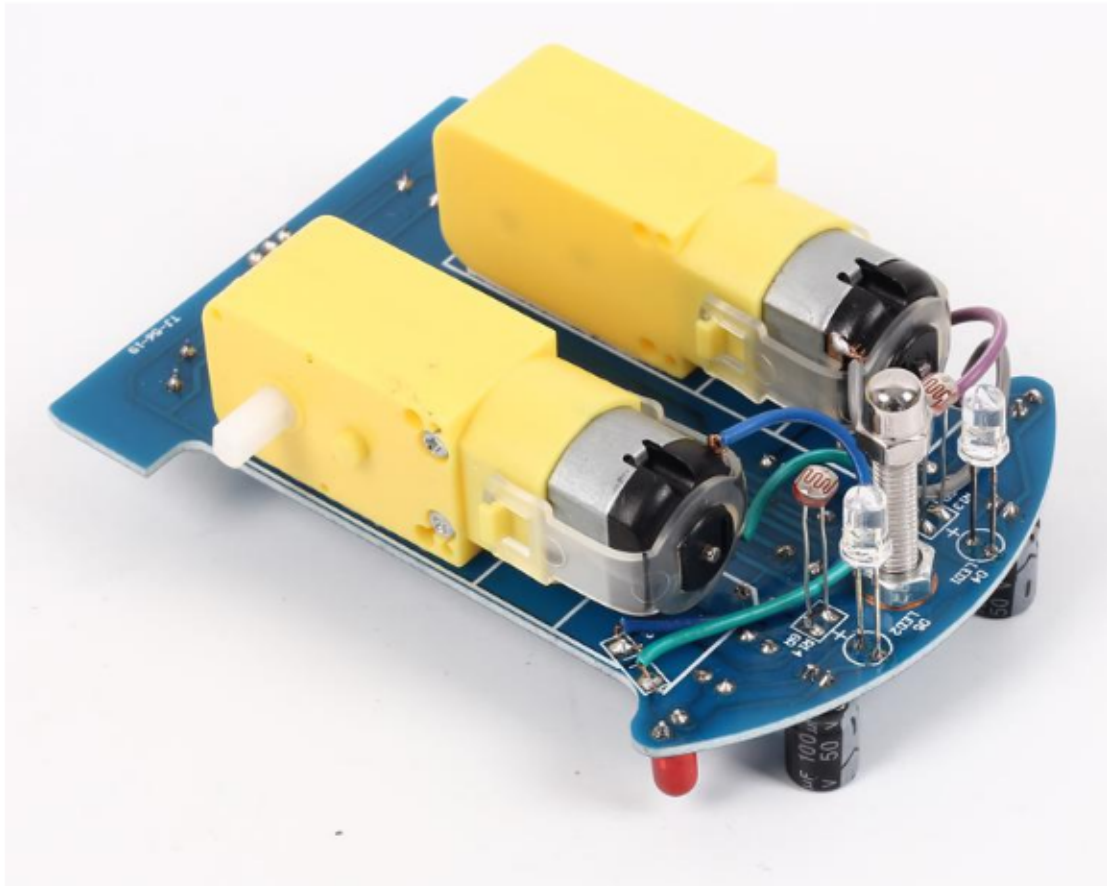

5>. Install battery case and wheel

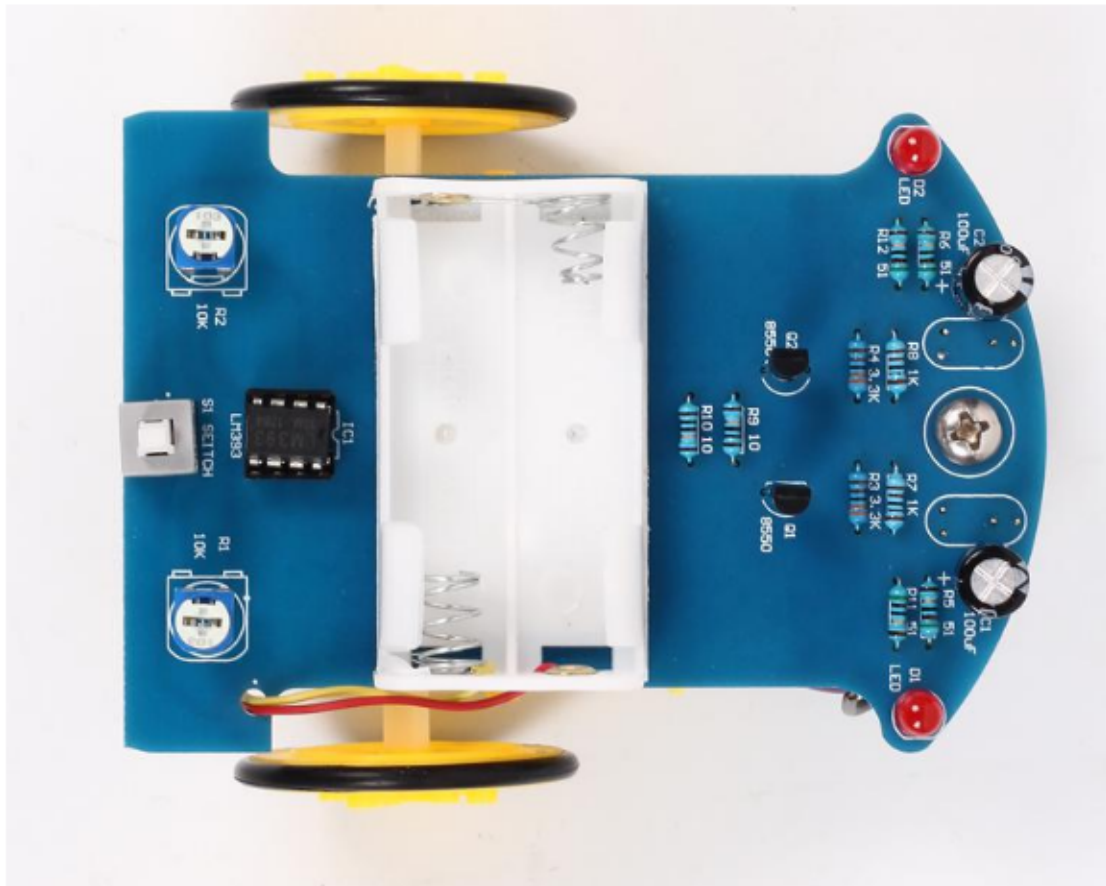

6>. Test.

6.1 Install 2pcs AA battery.

6.2 Press on switch.If 2pcs white LED ON,the installation is successful.If LED off,please check the welding.Pay attention to the direction of LED and other component and check pseudo Soldering.

6.3 Power on.Check S8550 or 10ohm resistor if motor don't move.

6.4 Install LM393(Pay attention to the direction of IC).

6.Effect demonstration

